



BENNETT MARINE



BOLT

Electric Trim Tab Systems



INSTALLATION & USER'S GUIDE

Important safety instructions: Read and save all instructions. This manual may periodically be subject to change. To ensure the most current version, visit BennettTrimTabs.com/Install.

Congrats!



Making an investment in Bennett Marine's durable and dependable spectrum of products will keep you enjoying the boating experience all the more. We've been a trusted name in the industry for over half a century with exceptional products built to perform, and to last. Get Bennett on board and **enjoy the ride!**

Behind You For The Distance

Bennett's legendary customer service and support is a priceless perk to your new purchase! Our expert staff with over 50 years of trim tab experience is ready to assist with your installation, help with troubleshooting, or answer any other of your questions along the way.

How to Contact Us

Call us at 866-894-1626 option #3, email BMI_Info@Yamaha-Motor.com, or go to BennettTrimTabs.com/Contact and fill out the online form. Please allow 24 hours for online requests. Our office hours are Monday through Friday from 8:00 a.m. to 5:00 p.m. (Eastern Standard Time).

The Benefits of Trim Tabs

Increase Visibility For A Safer Ride: Keeping your bow down at reduced speeds is important, especially in congested waters or foul weather. Bennett trim tabs enable you to plane at a much lower speed, operating your boat more safely.

Save Money With Better Fuel Efficiency: Getting up on plane quicker means your boat spends less time running inefficiently. Bennett trim tabs decrease engine laboring, dramatically improving your fuel economy and prolonging the life of the engine.

Maximize Performance While Smoothing Out The Ride: Bennett trim tabs enhance the operating economy of your boat by lifting the stern in proportion to speed, weight distribution, and fuel load changes.

Contents

| | |
|--------------------|---|
| Contacting Us..... | 2 |
|--------------------|---|

Parts List & Specifications

| | |
|---------------------------------------|---|
| BOLT Trim Tab System Parts List | 4 |
| System Specifications | 5 |

Trim Tab Overview & Operation

| | |
|-----------------------------------|---|
| How Trim Tabs Work..... | 6 |
| Special Conditions & Safety | 8 |

Installation Instructions

| | |
|---|----|
| Actuator & Trim Tab Installation | 10 |
| Helm Control Installation | 17 |
| Extension Cable Installation | 22 |
| Control Testing & Diagnostics | 23 |
| System Wiring Diagrams & Installation Templates | 24 |
| General Maintenance & Safety Precautions | 32 |
| Troubleshooting | 33 |

Warranty

| | |
|------------------------|----|
| Limited Warranty | 37 |
| Warranty Period | 38 |

Watch installation videos at BennettTrimTabs.com/BOLT



BOLT Electric Trim Tab System Parts

BOLT Electric Trim Tab Kits (12V)

CONTROLS SOLD SEPARATELY

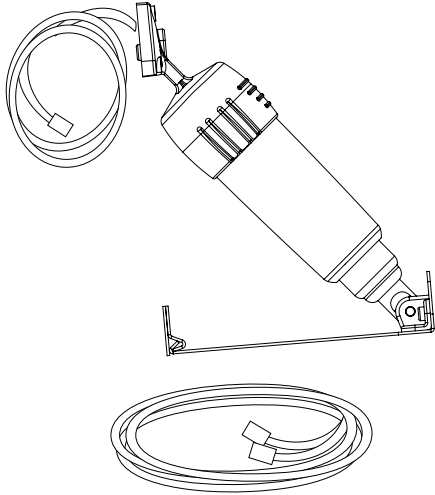

Kits Include:

- (2) 12-volt fixed upper hinge actuators with 6-ft. cables and waterproof connectors (BEA2000)
- (2) Stainless steel trim planes (tabs) (Interlocking hinge & backing plate)
- (2) 20-ft. wire harnesses with waterproof connectors (BAW2020)

| PN# | SPAN/CHORD | RETAIL BOX |
|----------|-------------------|------------|
| BOLT124 | 12"x4" | ✓ |
| BOLT129 | 12"x9" | ✓ |
| BOLT189 | 18"x9" | |
| BOLT249 | 24"x9" | |
| BOLT1212 | 12"x12" | ✓ |
| BOLT1812 | 18"x12" | |
| BOLT2412 | 24"x12" | |
| BOLTBLT | Tabs not included | |

BOLT Electric - Edge Mount Limited Space Trim Tab Kits (12V)

CONTROLS SOLD SEPARATELY

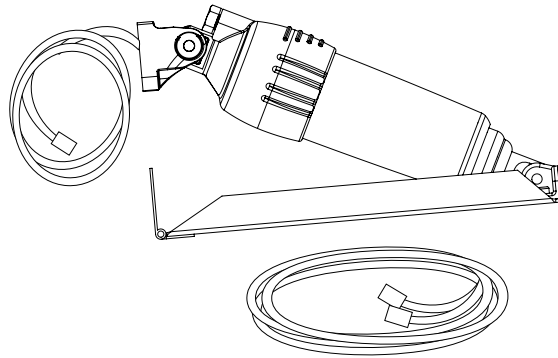

Kits Include:

- (2) 12-volt adjustable upper hinge actuators with 6-ft. cables and waterproof connectors (BEA3000)
- (2) Stainless steel trim planes (tabs) (Piano hinge & backing plate)
- (2) 20-ft. wire harnesses with waterproof connectors (BAW2020)

| PN# | SPAN/CHORD | RETAIL BOX |
|------------|-------------------|------------|
| BOLT612ED | 6"x12" | ✓ |
| BOLT912ED | 9"x12" | ✓ |
| BOLT1212ED | 12"x12" | ✓ |
| BOLTBLTADJ | Tabs not included | |

System Specifications

Trim Planes & Mounting Plates

Trim tab sizes vary. Stainless Steel, 304. Piano hinge, bottom mount, and transom mount available.

Actuators

2 models available:

BEA2000 Fixed Upper Hinge model:

Upper hinge material made of flexible nylon.

Remainder of actuator is made of high impact fiberglass-filled nylon. (12V or 24V)

BEA3000 Adjustable Upper Hinge model:

Made of high impact fiberglass-filled nylon.

Remainder of actuator is made of high impact fiberglass-filled nylon. (12V or 24V)

Relay Module (Sold separately)

Two types of relay modules with diagnostics are available. (With ATR only, or with LED & ATR, 12V or 24V).

Helm Control (Sold separately)

Controls on 12 volt systems circuit breaker or use 20 amp in-line fuse. (3 types of controls, see page 17).

Communications Junction Box (Sold separately)

Used only for dual station and/or dual actuator applications.

Standard Wire Harness Lengths

Actuators each come standard with 6 ft. cables, with waterproof connectors. The BOLT kit also includes (2) 20 ft. extension cables with waterproof connectors (Part# BAW20).

Optional Wire Harness Extensions (Sold separately)

Optional extension cables are available 5'-20' in 5 ft. increments (Part# BAW5, BAW10, BAW15, BAW20)

Helm controls sold separately. See page 17 for more information.
For help with installation, call us at 866-894-1626 option #3,
or email us at BMI_Info@Yamaha-Motor.com.

How Trim Tabs Work

Bennett trim tabs most often attach to the bottom edge of the transom (although other mounting variations are available). When the helm control is pressed, the trim tabs move up or down. Water-force on the trim tab creates an upward pressure, raising the stern and lowering the bow. Properly sized trim tabs improve the performance of your boat in a wide range of weight, weather and water conditions.

In general, trim tabs operate in reverse of what you may think (Figure 1). The port (left) button controls the starboard (right) tab. Conversely, the starboard (right) button controls the port (left) tab. The helm control is wired so that all you have to do is press the control in the direction you want the bow to move. Don't worry about which trim tab is moving. The proper use of Bennett Trim Tabs becomes second nature after a short time.

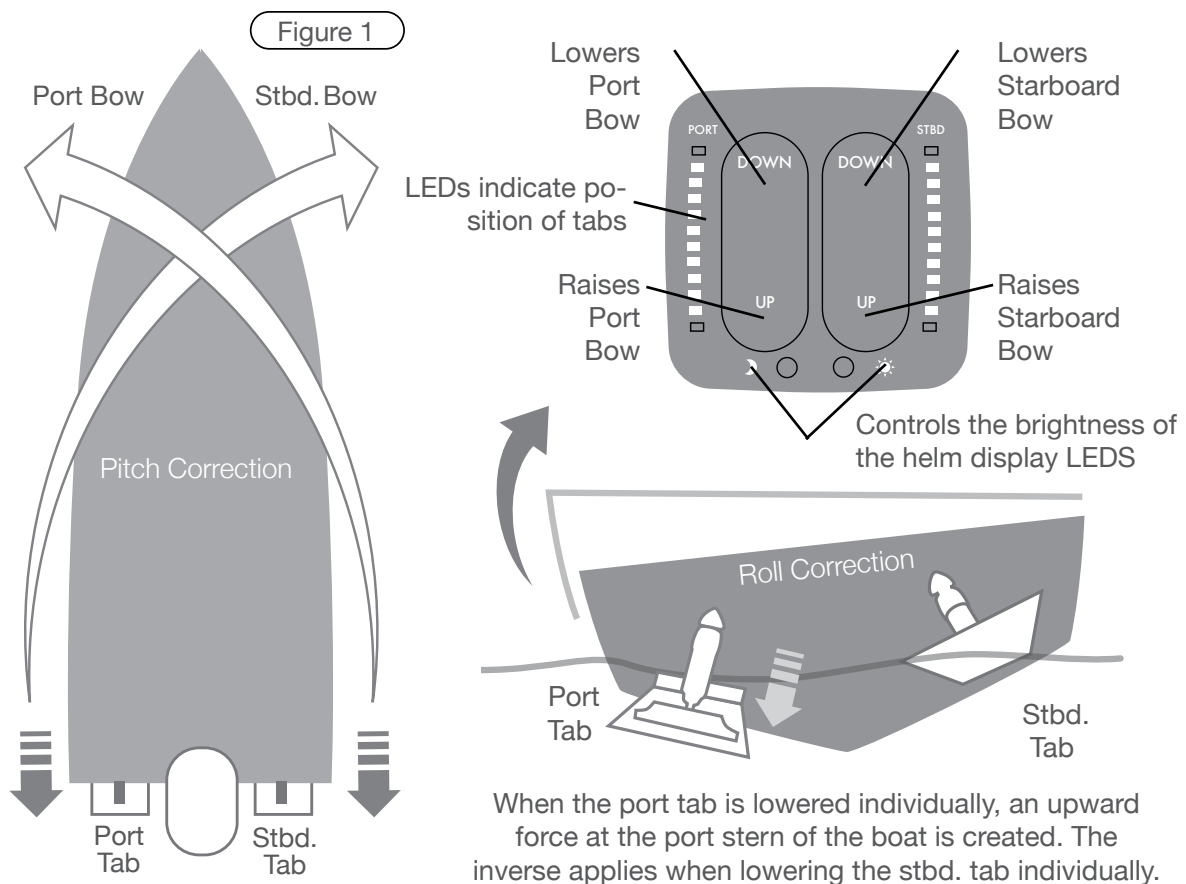

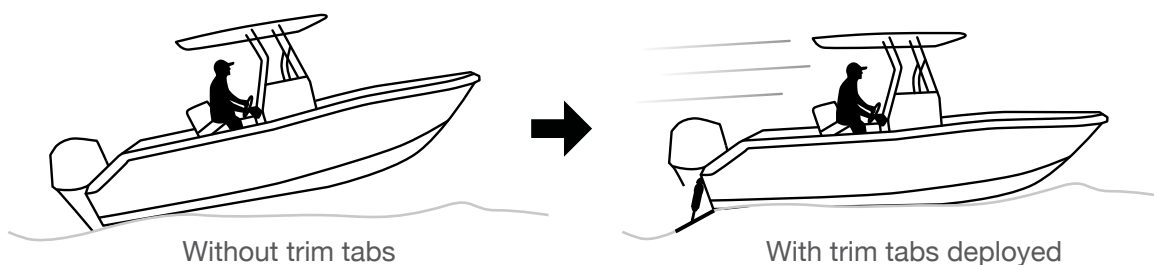

Getting and staying trimmed

Most boats break over (get on plane) at a particular speed. This speed is determined by weight distribution, and water conditions, etc.. Bennett trim tabs enable your boat to plane at speeds lower than the natural planing speed. By pressing the control to the BOW DOWN position, your trim tabs move down. This will raise your stern and lower your bow, getting you up on plane faster.

Optimum Attitude

A good way to find your boat's optimum attitude is to conduct a simple test. Run the boat lightly loaded, at full speed on flat water. Notice the bow in relation to the horizon. This should be your boat's best running attitude. Properly sized trim tabs can be used to recreate this optimum attitude regardless of weight distribution, speed or water conditions.

Getting Used to the Feel of Your Trim Tabs

When learning to use your tabs, begin by pressing the helm control in half second bursts for gradual trimming. Be careful not to over-trim your boat. An over-trimmed boat will plow or bow-steer. If you over-trim the boat, simply press BOW UP and the bow of the boat will rise.

Special Conditions & Safety Precautions

Correcting for a List

Bennett Trim Tabs may be operated individually so that you can correct for listing. Your control is designed so that you can use it intuitively. Do not think about what the trim tabs are doing, just concentrate on the bow. If the port bow is high, push the port side BOW DOWN direction. If the starboard bow is high, push the starboard side BOW DOWN direction. Press the control in half-second bursts to avoid over-trimming, allowing time between corrections for the boat to react.

Using In Conjunction With Outboard Trim/Tilt

Using your trim tabs in conjunction with your engine's power trim will give you increased speed and power.

1. Adjust the trim tabs to achieve a planing attitude.
2. Use the power trim to position the prop path parallel to the water flow as indicated by increased RPM / Speed.
3. If necessary, re-adjust the trim tabs to fine tune the trim of your boat.
In other words, use your trim tabs to trim the boat and your power trim to trim your prop.

Running In Rough Water

When running in a chop or heavy seas, press BOW DOWN on both tabs. This will bring the "V" of the hull in contact with the waves rather than having the waves pound the hull and your passengers.

Following Sea

For maximum control and maneuverability in a following sea or when running in an inlet, make sure the trim tabs are fully retracted by pressing BOW UP on both tabs. This brings up the tabs, decreasing lift in the stern, allowing the bow to rise. If tabs are deployed, the bow may dig.

Windy Chop

To raise the windward side of the boat press BOW UP on that side. If this is not sufficient, press BOW DOWN on the leeward side of the boat. This allows the windward side of the boat to rise and minimizes spray. Do not overtrim when attempting this.

Shallow Water / Hole Shot

To lift the stern and lower the bow, lower both tabs completely down by pressing BOW DOWN on both tabs. As you throttle up and speed increases, raise the tabs by pressing BOW UP on both tabs.

Porpoising

Porpoising is a condition more common in faster boats. As speed increases, the bow repeatedly rises out of the water until gravity overcomes lift and the bow falls down. Press “Bow Down” in half second bursts. As the trim tabs deflect, the porpoising subsides and your speed should remain the same or decrease. Only a slight amount of trim tab deflection should be necessary.

Safety Precautions

Bennett trim tabs have a significant effect on the operation and versatility of your boat. No one knows your boat better than you, so the best learning method is to spend time getting familiar with your boat’s reaction to the trim tabs. Remember, practice makes perfect! As your experience increases, so will your enjoyment. Always operate your boat with safety first in mind.

- Do not over-trim, particularly at high speeds as the bow will dig in and wave action may cause the boat to veer.
- While operating trim tabs, use caution. Improper use of trim tabs may cause accidents and/or injury.
- For best maneuverability, trim tabs should be fully retracted in a following sea, or when running in an inlet.

Actuator & Tab Installation

Getting Started

- The actuator and tab installation must be done when the vessel is out of the water. Do not attempt to install the actuators while the vessel is in the water as the actuators and tabs are mounted below the water line.
- Before performing any electrical work on a vessel, disconnect the battery by removing the positive (+) cable or if equipped, turn the battery disconnect switch to the OFF position.
- **Be sure to check for any obstructions:** Before starting installation and drilling any holes, verify that there are no mounting restrictions inside or outside the transom. Choose a location about 3-4" from the chine (side of the hull). Hold the tab up to the very bottom of the transom (1/8" from the hull bottom), and hold the actuator on the trim tab. Then set the actuator upper hinge against the transom. Verify this for both sides so that the actuators will not center on any obstruction. If they do, reposition tabs slightly inboard or outboard.

Standard "V" Hull Installation

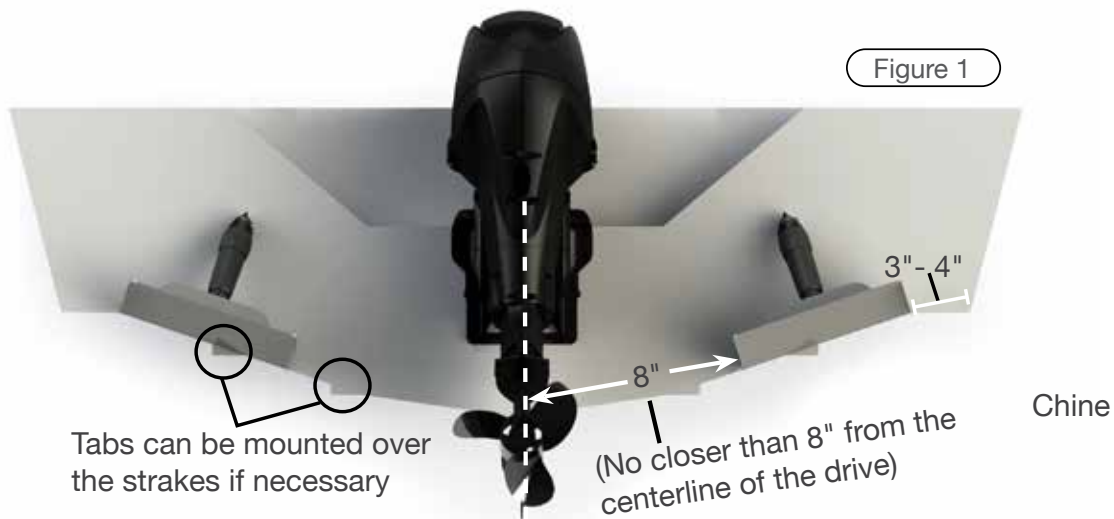

Tools and Materials List

- | | | |
|---|------------------------|------------------------------------|
| • 5/32", 9/16", 7/64" 3/8" & 3/16" drill bits | • Electric drill | • Marking pencil |
| • 2.5" (6.35 cm) or 1" (2.54 cm) hole saw (See pg. 28 & 29) | • Phillips screwdriver | • 4' (1.22 m) level |
| | • Marine epoxy | • 3M 5200 sealant or equivalent |
| | • Straight edge | • Tape measure |

Installing the Trim Tabs

Position the tab: Using the backing plate, choose a location 3-4" from the chine (see figure 1 on page 10). Maintain a minimum of 8" from the centerline of your drive unit to the closest edge of the trim tab. Align the bottom of the backing plate as per figure 2. The hole pattern on the backing plate should be closer to the bottom edge of the backing plate.

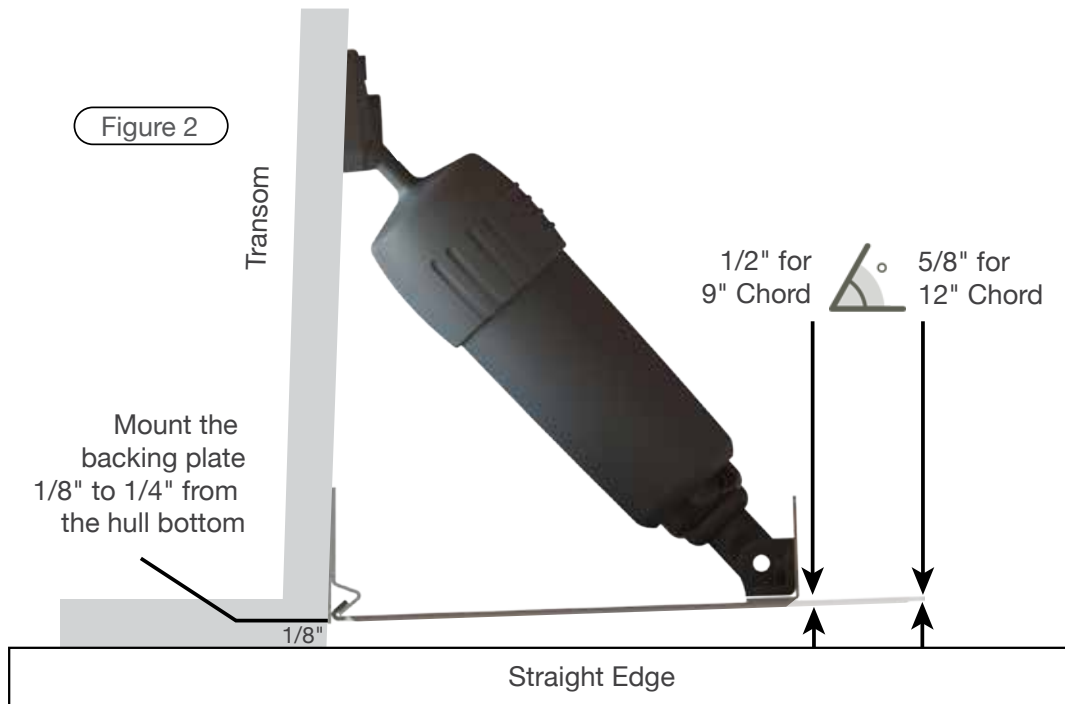

- Mark the pilot holes using the backing plate as a template. Make sure the tabs can be mounted in the same location on both sides.
- ▲ Verify that there are no mounting restrictions inside or outside the transom.
- Drill the mounting plate holes, using a 5/32" drill bit.

Actuator & Tab Installation continued

Installing the Actuators

- **Install the lower hinge to the actuator** using the supplied stainless steel pin.



- **Attach the actuator to the trim tab:** Secure the lower hinge with the supplied 1/4-20 x 3/4" Phillips Head machine screws.

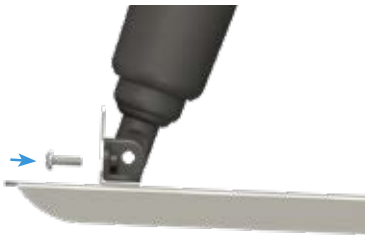

- **Install tab and hinge assembly:** Coat the threads of the #10 x 1-1/4" screws in 3M 5200 sealant (or equivalent) before inserting into the backing plate pilot holes. Install the screws in 3/4 of their length. Slide the trim tab between backing plate and hinge plate (Piano-hinged tabs will be pre-connected). Tighten the screws.



- **Set final actuator position:** Use a straight edge under the trim tab to make sure the correct negative angle for your size of tab is achieved (Refer to Figure 2 on page 11). This is important to ensure correct actuator placement (1/2" negative angle for 9" chord; 5/8" negative angle for 12" chord; 1" negative angle for 16" chord).
- Fold wires down, placing the actuator template (Pg. 30-31) under the actuator. Align the outside of the template with the perimeter of the upper hinge. Tape the template in place.
- **Mark actuator position on the transom:** Using the installation drilling templates on page 30-31, mark the three upper hinge hole centers and the center hole on the transom.
- **Drill actuator holes:** Using the drilling templates on page 30-31, drill the center hole, and three mounting holes. Be sure to verify whether your actuators have fixed or adjustable upper hinges as center hole sizes are different for each.
- Repeat the previous steps for the opposite side of the boat.

If your Bolt set came with adjustable upper hinge actuators (BEA3000), please skip to page 14 "Mounting Adjustable Upper Hinge Actuators (BEA3000) to the Transom."

Mounting Fixed Upper Hinge Actuators (BEA2000) to the Transom.

- Temporarily detach the actuator from the lower hinge by unscrewing the 1/4-20 x 3/4 screws.



- Carefully insert the end of the electrical wires through the wire hole in the transom.
- Apply 3M 5200 waterproof sealant on the mounting surface and around the wiring of the new actuator.

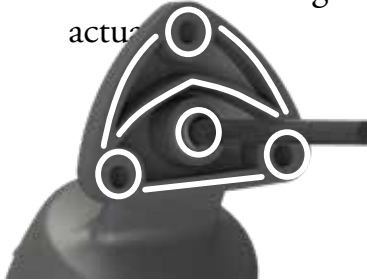

- Mount the upper hinge of the new actuator to the transom using the supplied #14 x1- 1/2" screws with a #3 Phillips head screw driver.
- Re-install the lower hinge mount to the trim tab using the (2)

supplied 1/4-20 x 3/4" and a #3 Phillips head screwdriver.

Do not use a power screw driver.

- On the inside of the transom, install the wiring connector onto the wires:
 - » Insert the white (blue on some systems) wire into location pin #1, insert the black (yellow on some systems) wire into location pin #2 into the back of the connector until the pin locks into place.

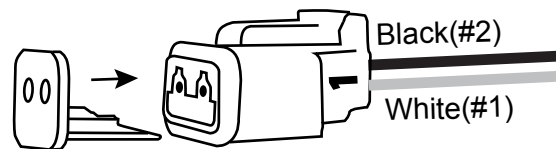

- » Install the orange wedge into the front of the connector.
- » Ensure the proper wire color is on the correct side of the connector.
- » For help with connectors visit BennettTrimTabs.com/ConnectorHelp.

Actuator & Tab Installation continued

Mounting Adjustable Upper Hinge Actuators (BEA3000) to the Transom

- Temporarily detach the actuator from the lower hinge by unscrewing the 1/4-20 x 3/4 screws.

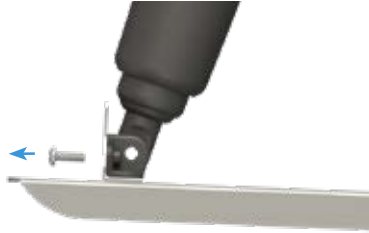

- Temporarily mount the upper hinge of the new actuator to the transom using (2) of the supplied #14 x 1-1/2" screws in the lower



Lower Mounting Positions

- Carefully insert end of the electrical cable through the adjustable upper hinge mount and install the sealing grommet onto the cable.



mounting positions, leaving a gap of 1/4" between the upper hinge and the transom. Pull the excess cable through the transom leaving enough cable to prevent the actuator from binding during its normal movement.

- Pull the cable through the upper hinge mount until the mount is about 8" from the actuator.
- Insert the end of the cable through the transom hole.
- Temporarily mount the actuator to the adjustable upper hinge using the supplied 5/16-18 bolt and lock nut to set the cable length.

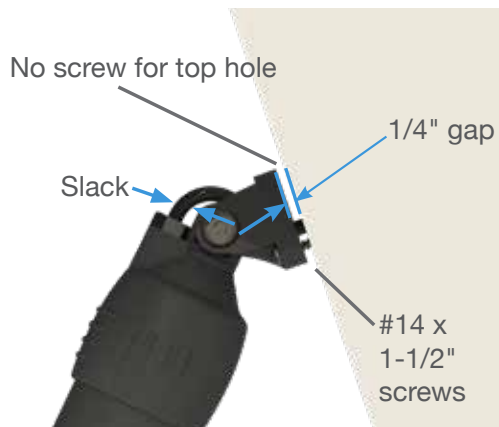

- Ensure that the cable sealing grommet is moved down the cable to its seat on the upper hinge.

- Swing the actuator through its maximum range of motion to ensure there is the proper amount of cable to allow movement without binding.



- Unscrew the two #14 x 1-1/2" screws holding the adjustable upper hinge and pull back from the transom making sure the cable length does not change.
- Apply 3M 5200 waterproof sealant on the mounting surface and around the wiring of the actuator.



- Screw the adjustable upper hinge to the transom using (2) of the supplied #14 x 1-1/2" screws in the lower 2 mounting positions.



- Remove the BOLT actuator from the upper hinge allowing the actuator to hang.



- Install the remaining (1) #14 x 1-1/2" screw into the top position of the hinge.
- Install the BOLT actuator to the upper hinge using the supplied 5/16-18 bolt and nut. Make sure not to over-tighten as the actuator needs to rotate within the hinge. Over-tightening will cause the actuator to bind. Do not collapse upper hinge mount uprights.
- Tighten until the bolt and nut contact the flanges of the upper hinge. There should be a gap between the uprights of the upper hinge mount and the flanges on the actuator.

Actuator & Tab Installation continued

- Re-install the lower hinge mount to the trim tab using the (2) supplied 1/4-20 x 3/4" screws and a #3 Phillips head screwdriver.



- **Do not use a power screw driver.**

Install the wiring connector onto the wires:

- » Insert the white (blue on some systems) wire into location pin #1, and the black (yellow on some systems) wire into location pin #2 into the back of the connector until the pin locks into place.

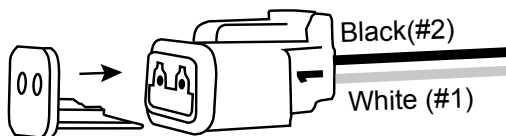

- » Ensure the proper wire color is on the correct side of the connector. The black actuator wire should match the black extension cable wire, and the white actuator wire should match the white wire harness wire.
- » Install the orange plastic wedge retainer into the front of the connector.
- » For help with connectors visit BennettTrimTabs.com/ConnectorHelp.

Helm Control Overview

Refer to wiring diagrams and installation templates beginning on page 24.
For information on BCI8000 visit BennettTrimTabs.com/Install

BRC – BOLT Rocker Switch Control (BRC4000)

This control is ergonomically and economically designed, water resistant, and provides a distinctive “click” when the trim tabs are engaged.
(See Pg. 18)

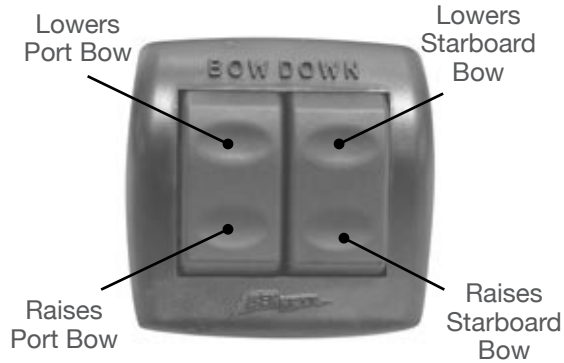

OBI - Integrated Helm Control (OBI9000E)

An attractive and user-friendly, stand-alone helm control without the need for an external control unit. The functionality and “brains” of the control unit are engineered directly into a single, space-saving, and simple-to-install keypad. Reduce bow rise, plane faster, and correct listing. (See Pg. 19)

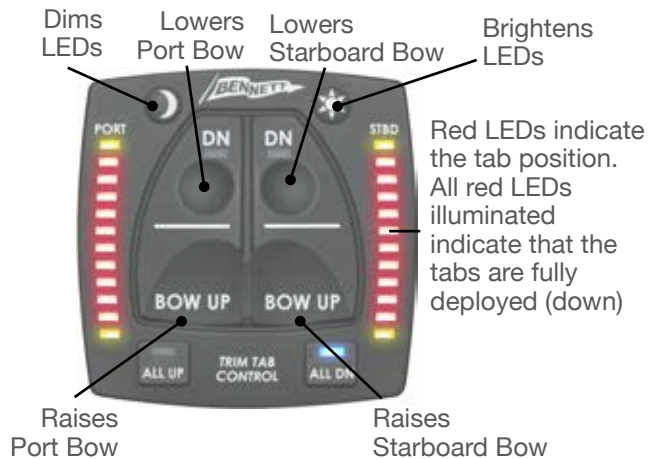

AutoTrim Pro with Indication & Automatic Control (AP000A1BC)

AutoTrim Pro is an all-in-one auto trim tab control system designed for boats of all sizes—packing a boatload of essential features into an easy-to-use, space-saving keypad. Reduce bow rise, improve visibility, correct listing—automatically.
(See Pg. 21)

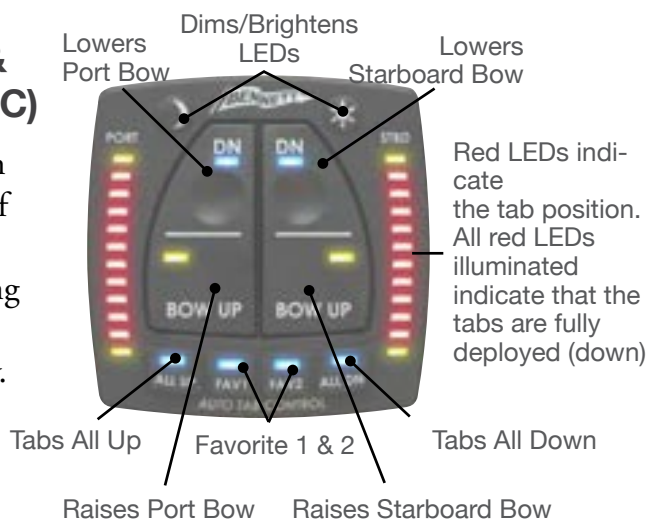

BRC BOLT Rocker Control (BRC4000)

Refer to wiring diagrams and installation templates beginning on page 24.



Before starting any work read the entire instructions, disconnect the battery(s), and verify that all power is turned off.

- Using the included template (Pg. 28), mark the locations for the 7/64" mounting holes and the 2.5" center hole.
- Check carefully ensure there are no obstructions behind the console before drilling.
- Using a 2.5" diameter hole-saw, drill the center hole. Use a 7/64" drill for the four mounting stud holes.
- Unsnap the bezel from the control plate.
- Remove the four (4) #8 screws from the hardware bag and insert into the holes on each corner of the control plate.
- Place the control plate onto the console, feeding the pre-connected wires through the 2.5" center hole while inserting the screws into each of the four holes.
- Once the control plate is properly seated, screw down the four (4) #8 screws (do not over-tighten) and snap the bezel back onto the plate assembly.
- The port cable on the rocker switch is marked with a red band. The starboard cable on the rocker switch is marked with a green band. **Note:** After the actuators are installed, the port cable (red band) will be connected to the extension cable coming from the port actuator, conversely the starboard cable (green band) will be connected to the extension cable coming from the starboard actuator.
- Plug the port black/white 20ft. extension cable (PN# BAW20) to the port connector on the BRC Rocker Control.
- Plug the starboard black/white 20ft. extension cable (PN# BAW20) to the starboard connector on the BRC Rocker Control.
- Connect the orange wire from the rocker switch to (+) 12V (20A) power and black wire to ground. Turn the battery on.
- For troubleshooting, see page 33

Integrated Helm Control (OBI9000E)

See wiring diagrams and installation templates starting on page 24.



- Before drilling any holes, read the entire instructions.
- Using the included drilling template, mark the location of the 2.5” center hole.
- Check carefully to ensure there are no obstructions behind the console before drilling.
- Using a 2.5” diameter hole saw, drill the center hole.
- Place the helm control into the console, feeding the cables through the 2.5” center hole.
- Once the helm control is properly seated, tighten the large lock nut hand tight (do not over-tighten).
- Plug the helm control cable marked with the red band to the port black and white twisted extension cable from the port actuator. Note: Some systems may use a blue and yellow twisted extension cable.
- Plug the helm control cable marked with the green band to the starboard black and white twisted extension cable from the starboard actuator. Note: Some systems may use a blue and yellow twisted extension cable.
- Connect the thicker orange (or red) wire from the helm control to (+) 12V (20A) power, and the black wire to ground. The power circuit must be protected with a 20A circuit breaker or fuse.
- Connect the purple wire from the helm control to the ignition to enable ATR (Auto Tab Retraction). When the ignition is powered off, the trim tabs will automatically retract.

Continued on next page

Integrated Helm Control (OBI9000E) continued.

- Connect the thin orange wire to helm power. This will turn the unit on and off.
- Please note: Although the tabs will auto-retract when the ignition is powered off, it is normal for the 4 corner LEDs to remain lit, and for the system to remain functional until battery power has been disabled.
- Troubleshooting Information can be found at BennettTrimTabs.com/OBI-Troubleshoot.

AutoTrim Pro with Indication & Automatic Control (AP000A1BC)

This control requires additional set up instructions. To view the complete installation and set-up instructions for AutoTrim Pro, visit BennettTrimTabs.com/Install and search "ATP".



- Before starting any work read the entire instructions, disconnect the battery(s), and verify that all power is turned off.
- Check carefully ensure there are no obstructions behind the console before drilling.
- Using the included template (Pg. 29), mark the locations for the 3/16" holes and the 1" center hole.
- Using a 1" diameter hole-saw, drill the center hole. Use a 3/16" drill for the four mounting stud holes.
- Place the helm display keypad onto the console, feeding the pre-connected wires through the 1" center hole while inserting the screws into each of the four holes.
- Once the control plate is properly seated, use the 4 white nylon thumb nuts provided to secure the display.
- Connect the orange wire to the power source for the gauges at the helm. This will power the control with all other dash devices.
- Connect the purple wire to the ignition switch (or any 12V circuit that turns ON and OFF with ignition) for auto tab retraction. This wire is used to initiate Auto Tab Retraction (ATR) when the ignition is switched to the OFF position. If ATR is not desired, this connection may be omitted.
- Locate a suitable ground. Connect the black wire from the ATP Helm Display to the ground source for the instrumentation.
- Locate a suitable dry, rigid location for the ATP Control Unit.
- Mount the Control Unit using the two #8 x 1/2" screws provided.
- Connect the orange and black power wires to a power source capable of supplying 20 Amps @ 12V or 10 Amps at 24V.
- Connect the communications cable from the ATP Helm Display to the communications cable on the ATP Control Unit.
- This control requires additional set-up steps. To view instructions, please visit BennettTrimTabs.com/Install and type "ATP".



Extension Cable Installation

Installing the Actuator Extension Cable

Please note that a relay module is only required for BCI and ATP controls. The BRC control does not require a relay module. The BRC control may be directly connected to the actuators using the helm display extension cable.

- An actuator extension cable may need to be run from each actuator to the location of the relay module.
- Note that the actuator extension cable has a male connector on one end and a female connector on the



other. The male end must go to the relay module, and the female end must go to the actuators.

- Carefully run the cables through the boat so that the female end is in close proximity to the actuators, and that the male end is in close proximity to the controls.
- Mark the cables to indicate port and starboard.
- Connect the port relay module extension cable to the port actuator, and the starboard extension cable to the starboard actuator.

Installing the Display Extension Cable

Please note that a display extension cable is only required for BCI and ATP controls. The BRC control does not require a relay module. The BRC control may be directly connected to the actuators using the helm display extension cable.

- A display extension cable may need to be run from the BCI/ATP helm display to the relay module.
- Note that the display extension cable has a male connector on one end and a female connector on the



other. The female end must go to the relay module, and the male end must go to the helm display.

- Carefully run the cables through the boat so that the female end is in close proximity to the helm display, and that the male end is in close proximity to the controls.

Reconnect the Battery

- Reconnect the positive (+) battery cable or turn the battery disconnect switch to the ON position and check the system for functionality.

For dual station or dual actuator applications, refer to the wiring diagrams beginning on page 24.

Control Testing/Diagnostics

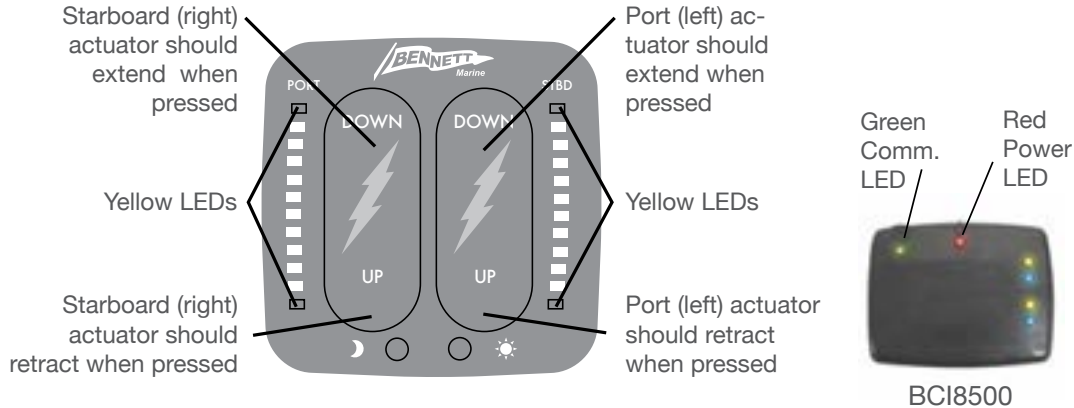

System Startup

- Turn the battery switch back on or reconnect the battery.
- Turn on the gauge switch.
- Turn on the ignition switch.
- Control should power up and the red power LED should be illuminated on the Relay Module.
- The green communications LED should be flashing on the Relay Module.
- Press the port "Bow Down" button. The starboard red LEDs should illuminate as the starboard actuator extends.
- Press the starboard "Bow Down" button. The port red LEDs should illuminate as the port actuator extends.
- Press the port "Bow Up" button. The starboard red LEDs should turn off as the starboard actuator retracts.
- Press the starboard "Bow Up" button. The port red LEDs should turn off as the port actuator retracts.
- If the system is not functioning as described above, refer to the troubleshooting section beginning on page 33.

Wiring Diagrams

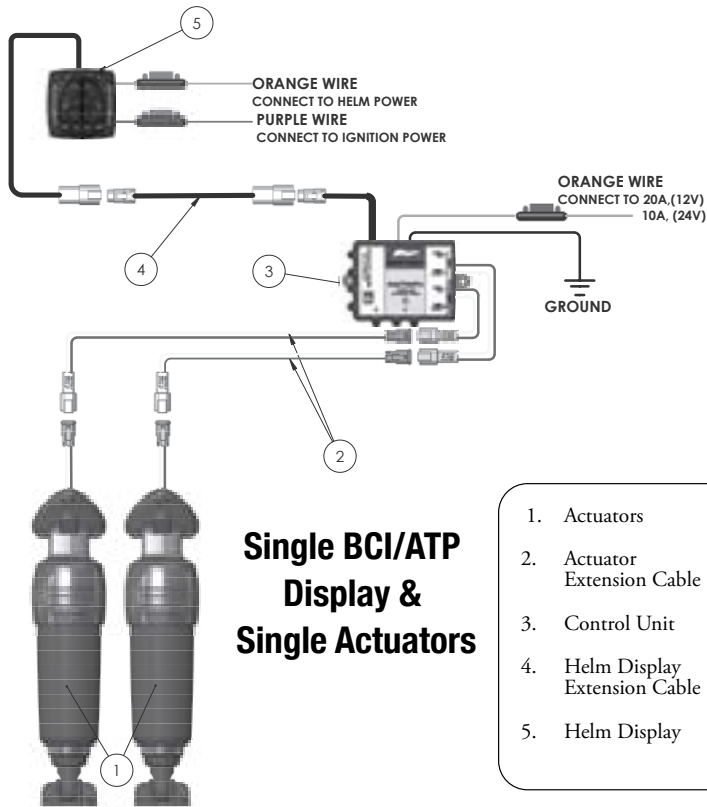

Single BRC Display & Single Actuators

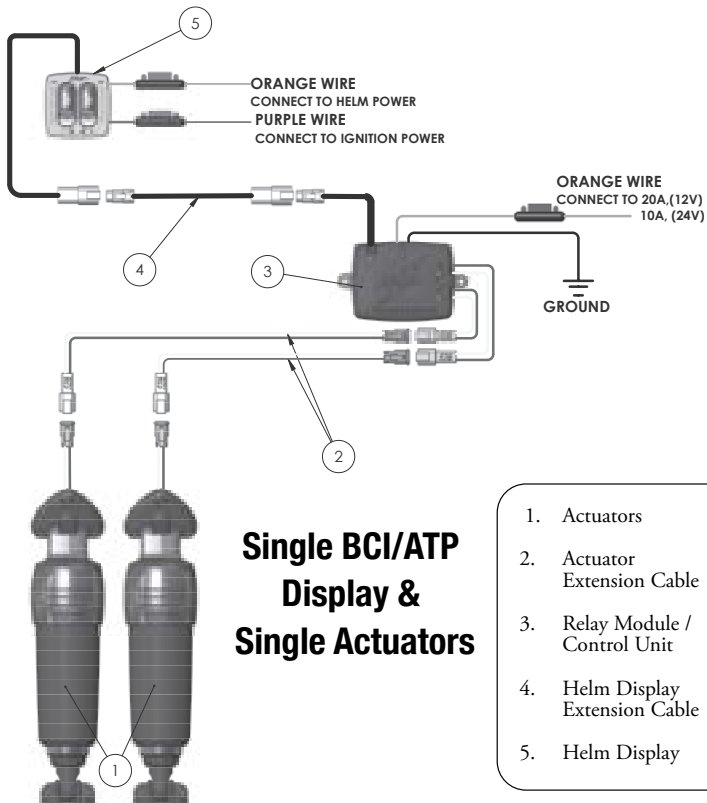
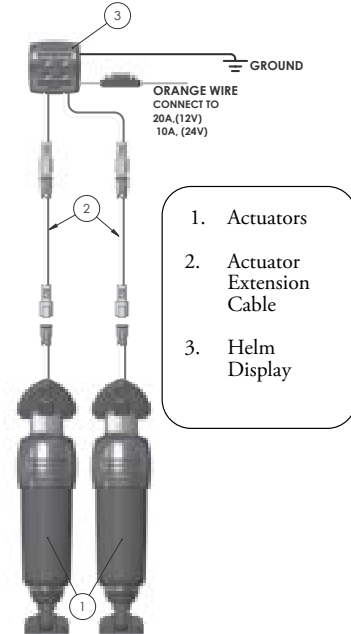

Single BRC Display & Single Actuators

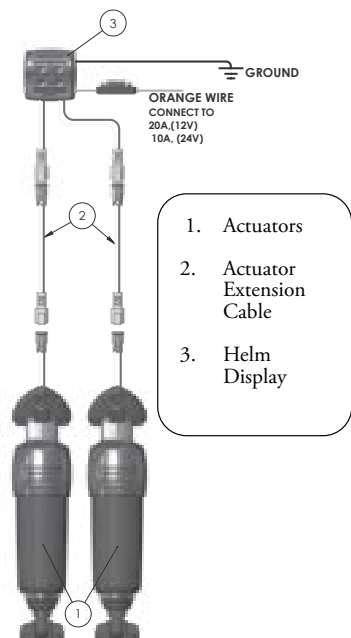

Wiring Diagrams

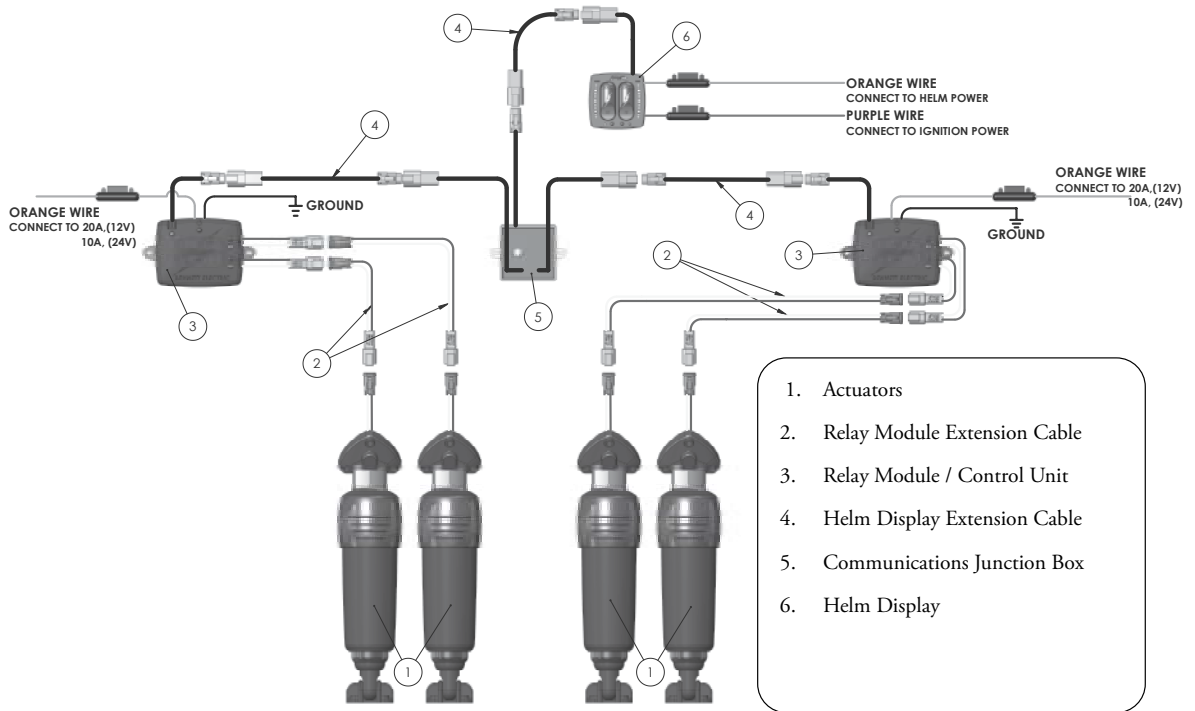

Single BCI/ATP Display & Dual Actuators

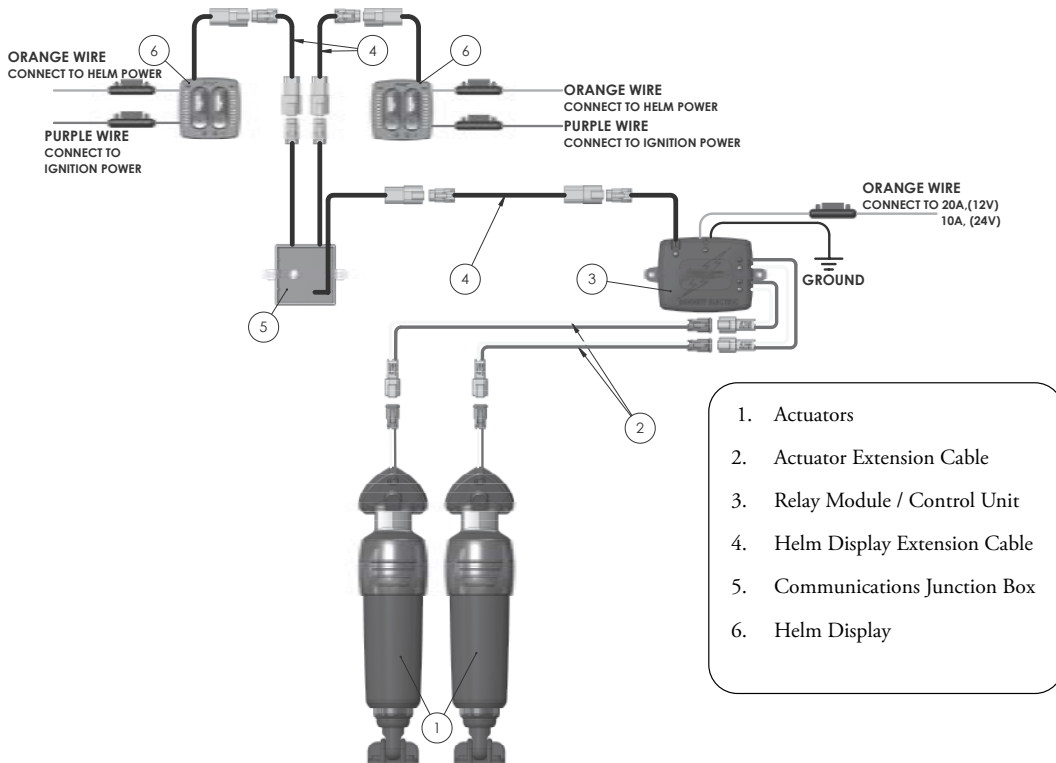

Dual BCI/ATP Display & Single Actuators

Wiring Diagrams

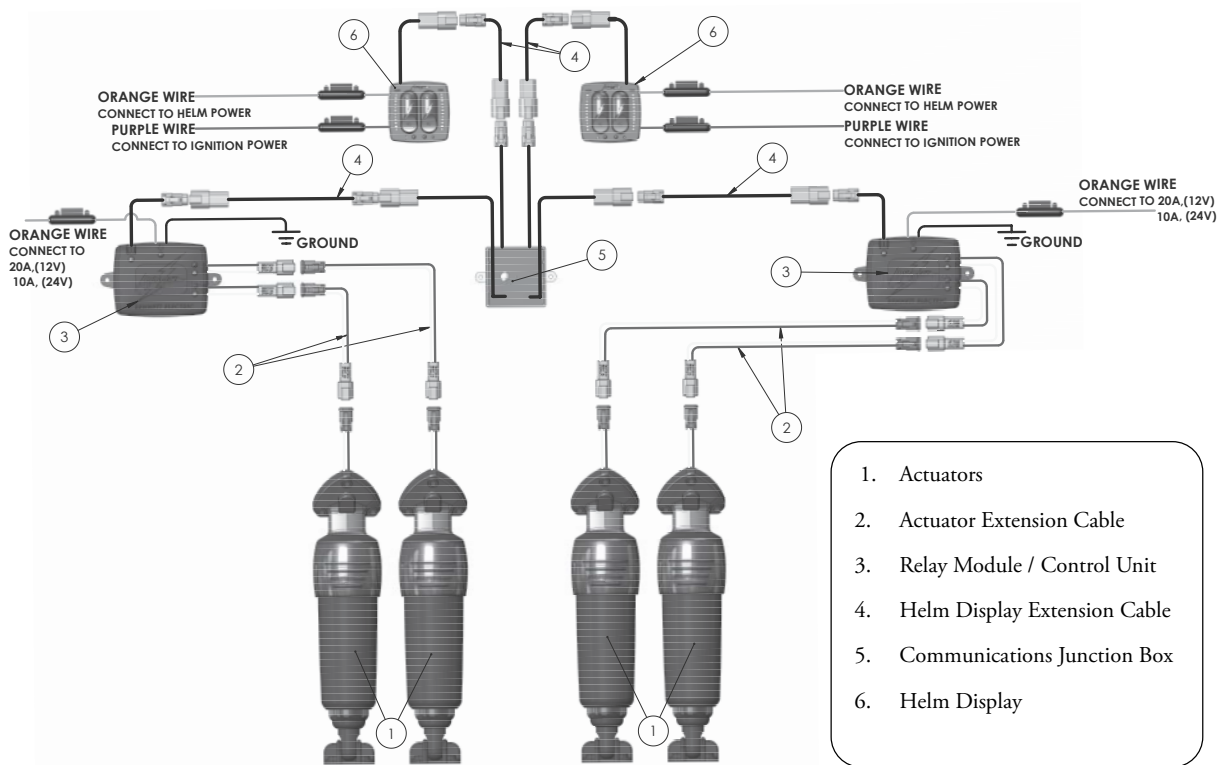

Dual BCI/ATP Display & Dual Actuators

Wiring Diagrams

Single OBI Display & Single Actuators

RED WIRE
CONNECT TO 20A (12V), 10A (24V)
PURPLE WIRE
CONNECT TO IGNITION
ORANGE WIRE
CONNECT TO HELM POWER

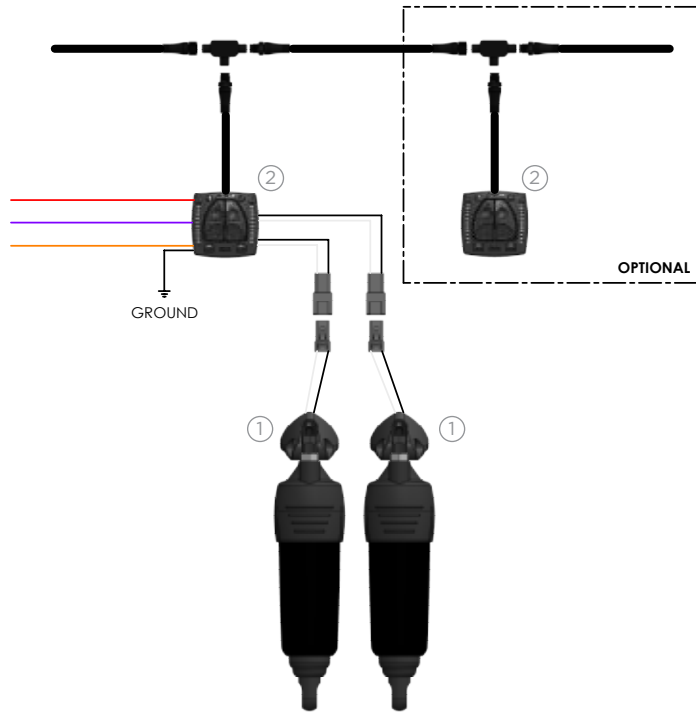

1. Actuators
2. Helm Display

Dual OBI Display & Dual Actuators

RED WIRE
CONNECT TO 20A (12V)
PURPLE WIRE
CONNECT TO IGNITION
ORANGE WIRE
CONNECT TO HELM POWER

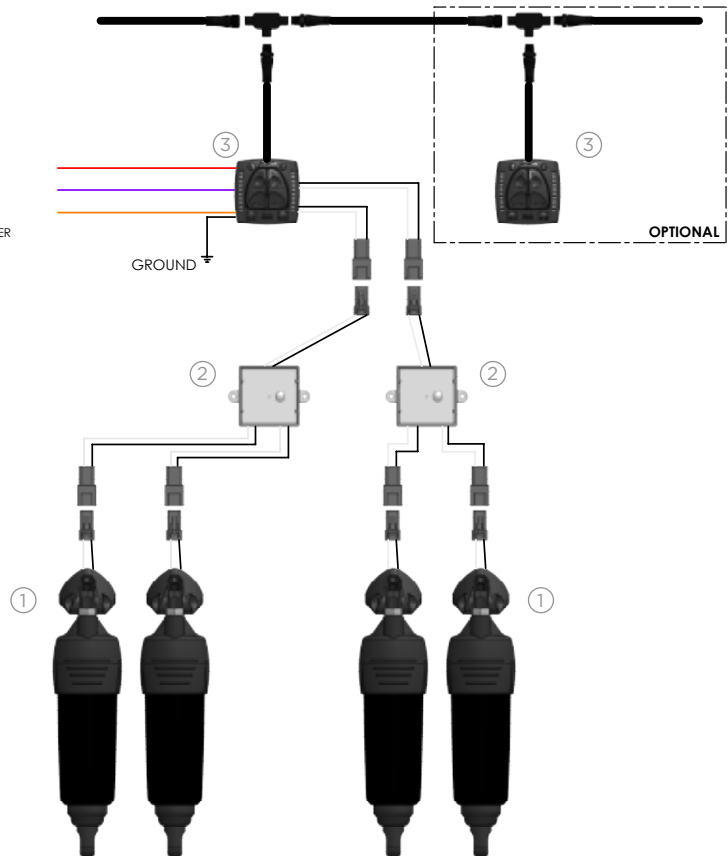

1. Actuators
2. Dual Electric Actuator Relay (12V)
DEARM – 6BT501044700
3. Helm Display

Templates

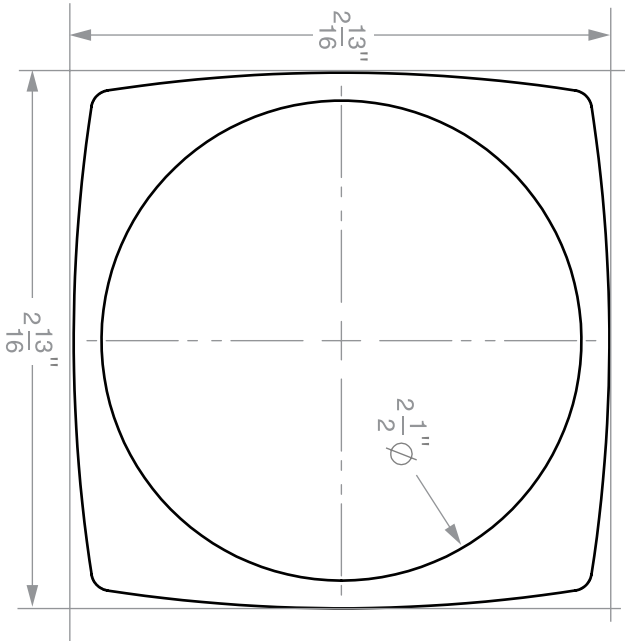

**OBI Control
Templates**

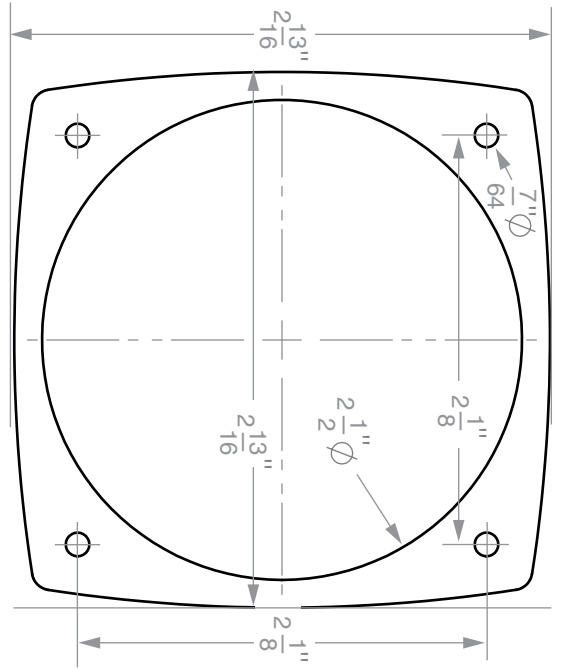
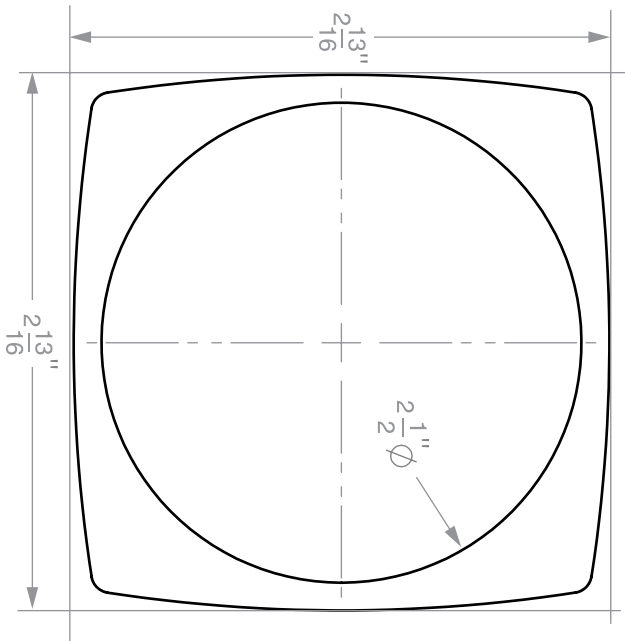

**BCI or
AutoTrim
Pro Control
Templates**

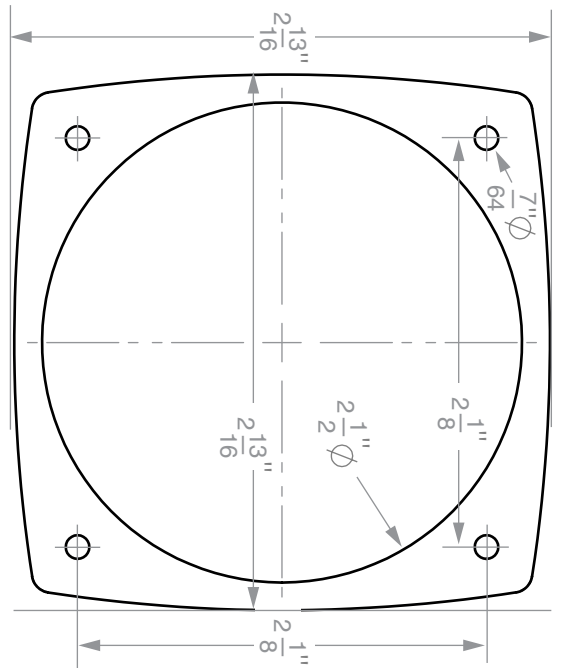

Must be printed/copied at 100% scale

1"

BCI or AutoTrim Pro Control Templates

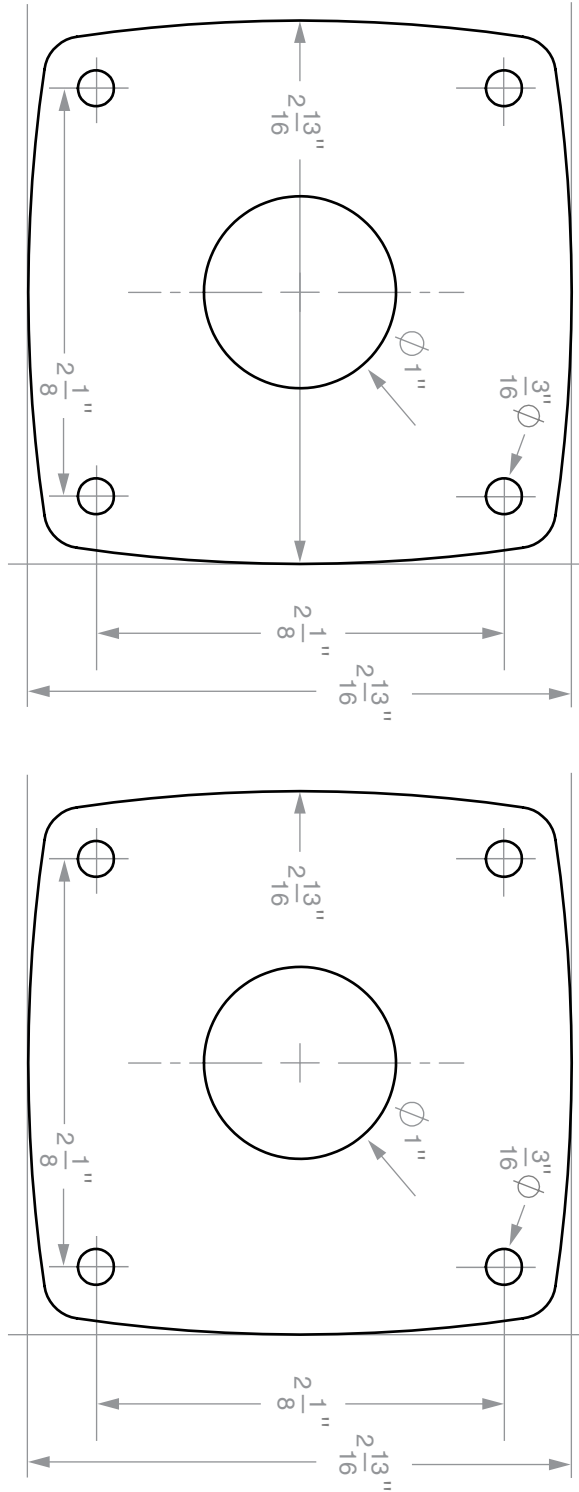

Must be printed/copied at 100% scale |  1"

BEA2000 BOLT Fixed Upper Hinge Templates

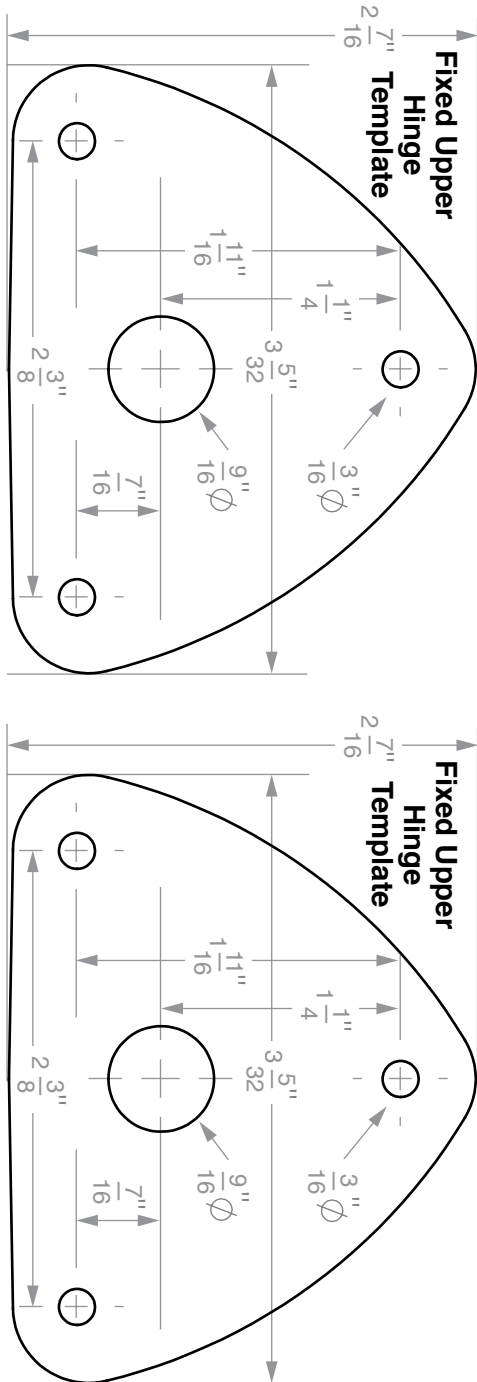

Must be printed/copied at 100% scale

1"

BEA3000 Adjustable Upper Hinge Templates

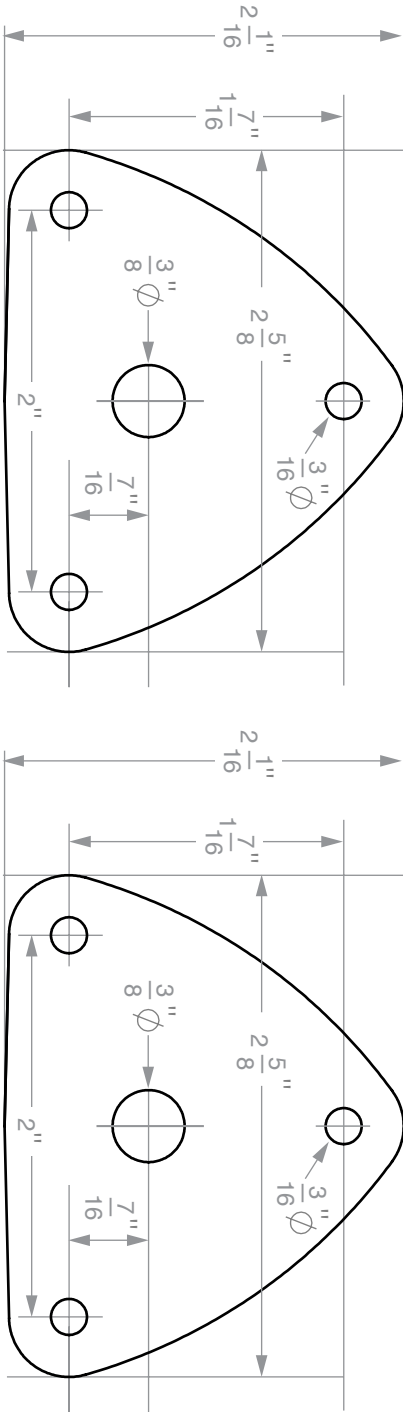

Must be printed/copied at 100% scale 

Maintenance

General Maintenance

- Periodically, check electrical connections behind switch.
- Cold temperatures do not affect the trim tab system. No winterization is necessary.
- **Note for saltwater only applications:** To deter electrolysis, a zinc anode should be attached to the top of each trim tab. Zinc must make direct contact with stainless steel. Do not paint zinc. Do not ground trim tabs to other underwater appendages.
- Paint trim tabs to discourage marine growth:
 - » Clean surface of all grease, oil, dirt.
 - » Apply two coats of epoxy metal primer.
 - » Apply two coats of anti-fouling paint. The actuator, including the piston, may be painted.

- Unpainted trim tabs may acquire an orange discoloration. **This oxidation of surface carbon molecules is normal.** The integrity of the stainless steel is not affected. Orange coating can be cleaned off, but may eventually return. Note: This discoloration should not be confused with the pitting and corrosion of electrolysis.

Safety Precautions

- Take immediate action to correct any malfunction or failure of your trim tabs.
- Occasionally, check for loose or corroded wiring connections.
- Stepping on the trim tab may cause damage to the unit, or injury.
- Leaving the actuator extended when the boat is not in use will not cause seal damage.
- **Refer to safety trim tab precautions on page 9**

Troubleshooting

The BOLT Electric Trim Tab system is built with the same rigid quality standards as all of the other Bennett product lines. Bennett stands behind its products, providing exceptional customer service and support.

Please feel free to call Bennett at 866-894-1626 option #3 or email BMI_Info@Yamaha-Motor.com for assistance in troubleshooting your particular issue. Bennett Marine Customer Service is available Monday through Friday, 8:00 a.m. to 5:00 p.m. Eastern Standard Time (EST).

Troubleshooting Systems with Rocker Switch Controls (BRC4000)

- **Problem:** Both tabs not moving.
 - » Check that batteries are turned on and charged
 - » Check fuse on orange wire to the rocker switch. (Fuse should be 20A for 12V systems and 10A for 24V systems)
 - » Check black ground wire on system to insure it is connected to the ground buss bar
 - » Check for voltage from the system being supplied to the orange wire use a volt-Ohm meter to check this
- **Problem:** One tab moves and one does not.
 - » On the actuator that is not moving, disconnect the actuator from the harness. Remove the orange wedge-lock from the connector using a small flat screwdriver. Inspect the connector contacts. The contact must be seated evenly and all the way up to the end of the connector for the mating pins to make contact. Push the wires up into the connector until the contacts snap in place. Replace the orange wedge-lock, reconnect the actuator to the extension cable and re-test.
- **Problem:** Actuator extends when BOW UP Button is pressed and actuator retracts when BOW DOWN is pressed.
 - » The actuator wires are reversed in the connector. Disconnect the actuator that is not moving properly. Remove the orange wedge-lock from the connector. Remove the contacts from the connector using a small straight blade screw driver to release the internal snaps. Re-insert the actuator wires into the connector in the reverse order. Re-insert the

orange wedge-lock into the connector. Reconnect the actuator to the extension cable and re-test.

- **Problem:** The PORT (left) Actuator extends when the PORT (left) BOW DOWN button is pressed and STBD (right) actuator extends when STBD (right) BOW DOWN button is pressed.
 - » The actuators are reversed. Unplug the actuators at the extension cable and switch the connections between the extension cables and the actuators.

Troubleshooting Systems with Indicator Controls (BCI8000)

- **Problem:** Both tabs not moving.
 - » Check that batteries are turned on and charged.
 - » Check that the red LED on the top center of the BCI relay module is on and bright.
 - » Verify that the green communications LED is flashing. If the green LED is not flashing, then there is no communication between the display and the relay module. Check the connector on the communications cable
- » If the red LED on the top center of the BCI relay module flashes dimly ever 3-5 seconds, then the power to the orange wire on the display is not connected
- » Verify that the power source to the orange wire on the display is turned ON. If this power is through the ignition, the ignition must be ON
- » If the red LED on the top center of the BCI relay module is completely off, then there is no power to the BCI relay module
- » Check fuse on orange wire to the BCI relay module. (Fuse should be 20A for 12V systems and 10A for 24V systems).
- » Check for voltage from the system being supplied to the orange wire. Use a volt-Ohm meter to check black ground wire on system to insure it is connected to the ground buss bar.
- » Check that the green communications LED in the top left corner of the BCI is flashing.
 - » If the green LED is not flashing, then there is no communications between the

display and the relay module.

- » Check to insure the display is connected at the relay module.
- » If a display extension cable is used, check the connections at the relay module and at the display.
- » If the red power LED is illuminated and the green power LED is flashing and the system is still not working, please contact Bennett Marine Client Services.
- **Problem:** One tab moves and one does not.
 - » On the actuator that is not moving, disconnect the actuator from the harness. Remove the orange wedge-lock from the connector and inspect the connector contacts. The contact must be seated evenly and all the way up to the end of the connector for the mating pins to make contact. Push the wires up into the connector until the contacts snap in place. Replace the orange wedge-lock, reconnect the actuator to the extension cable and retest.
- **Problem:** Actuator extends when

BOW UP Button is pressed and actuator retracts when BOW DOWN is pressed.

- » The actuator wires are reversed in the connector. Disconnect the actuator that is not moving properly. Remove the orange wedge-lock from the connector. Remove the contacts from the connector using a small straight blade screw driver to release the internal snaps. Re-insert the actuator wires into the connector in the reverse order. Re-insert the orange wedge-lock into the connector. Reconnect the actuator to the extension cable and re-test.
- **Problem:** The port (left) Actuator extends when the port (left) BOW DOWN button is pressed and stbd. (right) actuator extends when stbd. (right) BOW DOWN button is pressed.
 - » The actuators are reversed. Unplug the actuators at the extension cable and switch the connections between the extension cables and the actuators.
- **Problem:** One or two of the upper yellow LEDs on the control is flashing

- » The system did not detect an actuator on the side that is flashing
- » Check to insure that the actuators are plugged into the extension cables, and the extension cables are plugged into the relay module.
- » On the actuator that is not moving, disconnect the actuator from the cable. Remove the orange wedge-lock from the connector and inspect the connector contacts. The contact must be seated evenly and all the way up to the end of the connector for the mating pins to make contact. Push the wires up into the connector until the contacts snap in place. Replace the orange wedge-lock, reconnect the actuator to the extension cable and retest.

If the actuators still do not operate after following any of the steps above - STOP and call Bennett for further assistance at 866-894-1626 option #3, Monday through Friday, 8:00 a.m. to 5:00 p.m. (EST). Or email us anytime at BMI_Info@Yamaha-Motor.com.

Troubleshooting Systems with AutoTrim Pro (AP000A1BC)

Please visit BennettTrimTabs.com/ Install and search "ATP"

Bennett Marine Warranty (US Only)

We at Bennett Marine, (Bennett) are committed to product quality and customer satisfaction. We've supported our products for more than half a century and have earned a reputation for exceptional service and support. In keeping with that tradition Bennett provides a Limited Warranty for its Products. Please see the table on page 39 for our Warranty details.

Limited Warranty: Bennett warrants to the original purchaser and subsequent owners, that Bennett will repair or replace, at the discretion of Bennett, any part or component manufactured by Bennett which is proven to the satisfaction of Bennett to be defective, and which failure has occurred under normal use and within the warranty period. This Limited Warranty does not apply to products that have been damaged, or which fail, as a result of causes other than manufacturing defects (such as but not limited to electrical overloads, electrolysis, casualty, fire, collision, improper installation, lack of maintenance, exposure to elements, alteration, or misuse). This warranty does not cover damage to finishes. The warranty commences from the first date a product is purchased by the customer. If the product is installed on a boat by an OEM then the warranty commences on the first day on which the first retail customer purchases the boat. This warranty applies exclusively to products purchased and used in the United States.

Disclaimer And Exclusion Of Warranties: This warranty is meant to be a complete and exclusive statement of the terms of all express warranties offered by Bennett. To the extent permitted by law, there are no warranties, express or implied, including any implied warranties of merchantability or fitness for a particular purpose extended by Bennett other than the express warranty set forth in this instrument. Some states do not allow the exclusion of, or limitations to, implied warranties so the above limitation may not apply to you.

Warranty Claim Procedure: To make a claim please call Bennett Marine at 866-894-1626 option #3 to trouble-shoot the issue and start the claim process. You will be asked to complete a form that can be found online at BennettTrimTabs.com/Warranty and return the part for warranty evaluation. Parts will be evaluated upon receipt and any part found to meet the above warranty criteria will be repaired or replaced at Bennett's option. Replacement or repaired part will be shipped at no cost to customer via ground freight to US destinations only. Any expedite methods will be at customers expense.

Transferability: Before expiration of the warranty period, this Limited Warranty is fully transferable to subsequent owners of the boat on which it is originally installed and is void if the product is removed and reinstalled on another boat or is used for purposes for which it was not originally purchased.

Limitation And Exclusion Of Remedies: Bennett's sole responsibility shall be the repair or replacement, at its option, of any defective part or component. In certain instances Bennett reserves the right to provide refurbished parts. Customer agrees that this is the sole and exclusive remedy under this Limited Warranty. Bennett will not be responsible for any incidental, consequential or indirect damages, including loss of use as a result of any manufacturing defect in a product. Bennett will not be responsible for labor, haul out, or any other fees associated with the removal or installation of warranted part. Some states do not allow the exclusion or limitation of incidental or consequential damages, so this limitation may not apply to you.

Bennett Marine Warranty (US Only) continued

Product modification: Bennett reserves the right to change, modify or improve the products without obligation to incorporate such changes in products previously sold or installed. With respect to components or products replaced under this warranty, Bennett Marine reserves the right, in its sole discretion, to provide updated or current model components or products.

Warranty Period For Bennett Products: ***Please note, products not listed on the above table are not covered under Bennett's Limited Warranty.

***Limited Lifetime Warranty refers to the life of the product, not the boat, or the owner. Limited Lifetime Warranty ends when the product becomes unusable for reasons other than manufacturing defects.

Return Procedure For Customers Outside Us: For international returns, please refer to our worldwide distributor map on our website BennettTrimTabs.com/find-a-dealer to contact your local Bennett Marine distributor for warranty and returns procedures in your respective country.

| PRODUCT | PERIOD | COMMENCEMENT |
|-------------------------------|------------------|------------------------|
| Bolt Electric Actuator | Limited Lifetime | Purchased after 9/1/15 |
| Control Switches | 3 years | Purchased after 9/1/15 |

EXCEPTIONAL TRIM TAB SYSTEMS.

UNMATCHED RELIABILITY

Hydraulic & electric systems for boats across the spectrum

HYDRAULIC



ES2000 EIC5000 AP000A1HA

ELECTRIC



BRC4000 JOY1000 OBI9000E AP000A1BC

BOLT Electric Trim Tab Kits



BOLT Electric Edge Mount Trim Tab Kits



Hydraulic-to-Electric Conversion Kit



Lenco-to-Bennett Electric Conversion Kit



Hydraulic Trim Tab Kits



Self-leveling Trim Tab Kits



Premier Line Hydraulic Trim Tab Kits



Learn more at BennettTrimTabs.com



Bennett Marine, Inc.

550 Jim Moran Boulevard, Deerfield Beach, FL 33442, USA



866-894-1626 option #3
M-F 8am to 5pm (EST)



BennettTrimTabs.com



BMI_Info@Yamaha-Motor.com

Download your owners instruction manual at

BennettTrimTabs.com/Install

Or  scan this



Watch installation videos at BennettTrimTabs.com/BOLT



Benefits you can feel. Reliability you can trust.